

SETC Series

Spring Engaged Tooth Clutches

Eight standard frame sizes available:

- 3 to 10.5" diameter ; 2 to 7.5" length
- Bore sizes from 0.5 to 4.25"
- Static torque from 20 to 2600 lb-ft
- 1400 to 3500 RPM max speed
- Operates both dry and in oil
- Modified designs and customized assemblies available

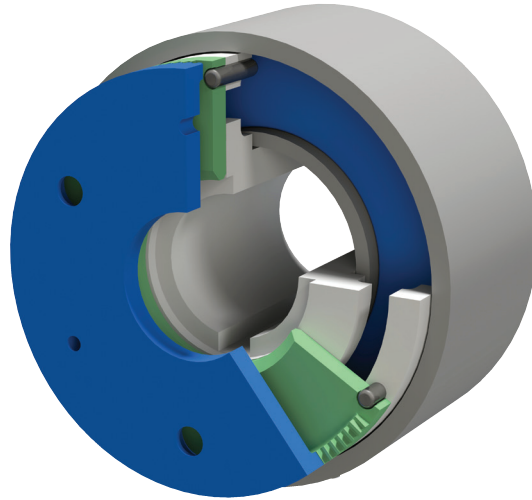

Performance/Mechanical Specifications

SETC Series — Model Size

		320	375	450	525	630	760	895	1065
Torque Rating (Static)*	lb-ft	20	40	80	160	320	650	1300	2600
	Nm	27.1	54.2	108.5	216.9	433.9	881.3	1762.6	3525.1
Recommended Max Speed	RPM	3500	3000	2500	2000	1600	1500	1400	1400
Coil Data – 24VDC									
	110VDC								
Rotor Inertia	Amps	1.0	1.2	2.0	2.6	3.9	5.7	7.5	11.5
		0.2	0.2	0.4	0.4	0.8	1.1	1.6	2.2
Output Plate Inertia	lb-ft ²	0.010	0.020	0.030	0.070	0.160	0.400	0.700	1.800
	kg-cm ²	4.214	8.428	12.642	29.498	67.424	168.561	294.982	758.524
Approximate Weight	lb	3.0	5.0	8.0	12.0	23.0	37.0	48.0	100.0
	kg	1.36	2.27	3.63	5.44	10.43	16.78	21.77	453.59

*Refer to Design Considerations – General Notes & Data for dynamic rating.

SETC Operation:

When current is applied to the coil in the stationary magnet body (held in place by an anti-rotation pin), a magnetic field is created which attracts the armature toward the rotor, disengaging the teeth.

When the current is removed, springs push the armature into engagement with the output plate and torque is transmitted.

Power On — Clutch Disengaged

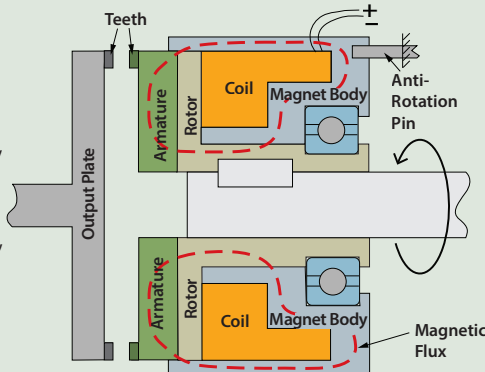

Power Off — Clutch Engaged

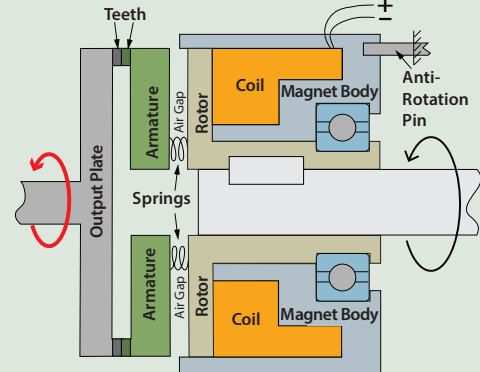

Tooth Clutches & Brakes

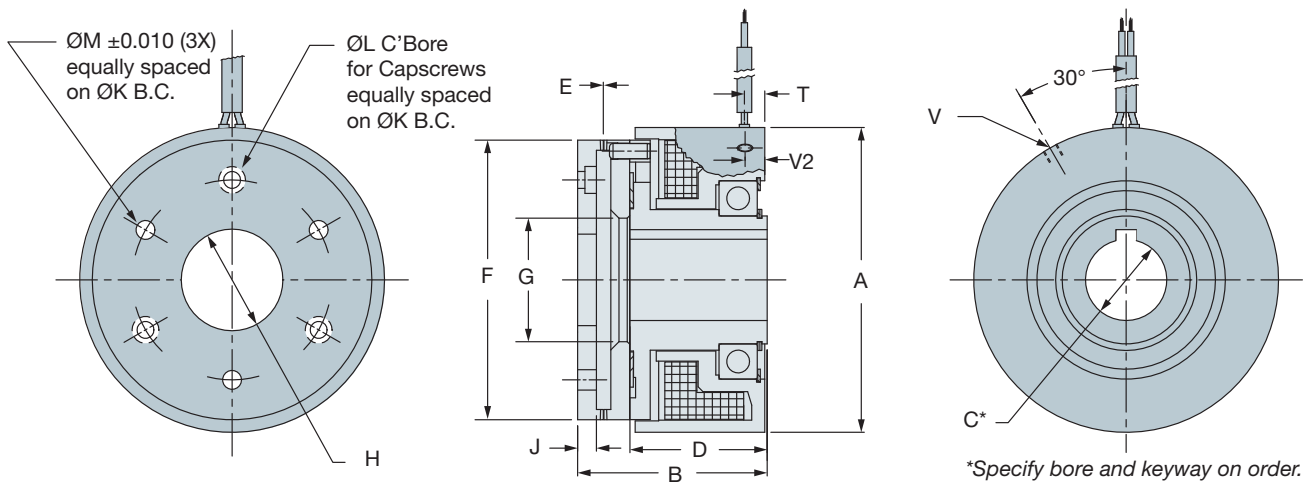

SETC Series — Model Size

Dimensions — Inches (mm)		320	375	450	525	630	760	895	1065
Magnet Body Diameter	A	3.16 (80.26)	3.75 (95.25)	4.50 (114.30)	5.25 (133.35)	6.32 (160.53)	7.60 (193.04)	8.94 (227.08)	10.65 (270.51)
Overall Length (ref)	B	2.07 (52.58)	2.33 (59.18)	2.61 (66.29)	2.94 (74.68)	3.55 (90.17)	4.93 (125.22)	6.04 (153.42)	7.48 (189.99)
Rotor Bore	Min	C* (12.700)	0.750 (19.050)	1.000 (25.400)	1.125 (28.575)	1.375 (34.925)	1.750 (44.450)	2.250 (57.150)	2.750 (69.85)
	Max	C* (25.400)	1.250 (31.750)	1.500 (38.100)	1.750 (44.450)	2.250 (57.150)	2.750 (69.85)	3.500 (88.900)	4.250 (107.95)
Length (ref)	D	1.49 (37.85)	1.69 (42.93)	1.85 (46.99)	2.06 (52.320)	2.48 (62.99)	2.97 (75.44)	3.37 (85.60)	4.10 (104.14)
Disengaged Clearance	E	0.010 (0.254)	0.012 (0.305)	0.012 (0.305)	0.012 (0.305)	0.012 (0.305)	0.016 (0.406)	0.018 (0.457)	0.020 (0.508)
Armature	Diameter	F (72.90)	3.44 (87.38)	4.11 (104.39)	4.78 (121.41)	5.75 (146.05)	6.97 (177.04)	8.19 (208.03)	9.66 (245.36)
	Bore	G (32.00)	1.26 (38.61)	1.52 (47.50)	1.87 (54.10)	2.13 (69.60)	2.74 (86.61)	3.41 (109.47)	5.18 (131.57)
Mounting Adapter	Bore (min.)	H (25.400)	1.000 (28.575)	1.125 (31.750)	1.250 (34.925)	1.375 (41.275)	1.625 (50.800)	2.500 (63.500)	2.750 (69.85)
	Bore (max.)	H (42.926)	1.690 (50.800)	2.000 (59.436)	2.340 (70.104)	2.760 (84.328)	3.320 (104.648)	4.120 (127.000)	5.875 (149.225)
Mounting Adapter	Thickness	J (6.10)	0.24 (7.87)	0.31 (9.14)	0.36 (10.67)	0.42 (13.21)	0.52 (15.49)	0.61 (19.05)	1.00 (25.40)
	Bolt Circle	K (53.85)	2.12 (62.48)	2.46 (72.90)	2.87 (86.87)	3.42 (101.60)	4.00 (124.46)	6.00 (152.40)	7.00 (177.80)
	Holes-Screw (Qty)	L	#10 (3)	#10 (3)	1/4 (3)	5/16 (3)	5/16 (3)	3/8 (3)	7/16 (3)
	Holes - Dowel	M (2.794)	0.110 (5.969)	0.235 (7.544)	0.297 (9.144)	0.360 (9.144)	0.360 (10.719)	0.422 (12.319)	0.485 (12.319)
Lead Wire Location	T (5.59)	0.22 (6.35)	0.25 (7.11)	0.28 (8.64)	0.34 (9.91)	0.39 (9.91)	0.39 (12.95)	0.51 (14.48)	
Anti-Rotation Hole	Depth - Max	V (7.37)	0.29 (8.38)	0.33 (8.64)	0.34 (11.94)	0.47 (13.46)	0.53 (16.51)	0.65 (19.05)	0.86 (21.84)
	Thread Size		#10-32	#10-32	1/4-20	1/4-20	3/8-16	3/8-16	3/8-16
	Location	V2 (5.59)	0.22 (6.35)	0.25 (7.11)	0.28 (8.64)	0.34 (9.91)	0.39 (9.91)	0.51 (12.95)	0.57 (14.48)