

SFTC Series

Stationary Field Tooth Clutches

Eight standard frame sizes available:

- 3 to 10.5" diameter ; 2 to 7.5" length
- Bore sizes from 0.5 to 4.25"
- Static torque from 40 to 5200 lb-ft
- 1400 to 3500 RPM
- Operates both dry and in oil
- Modified designs and customized assemblies available

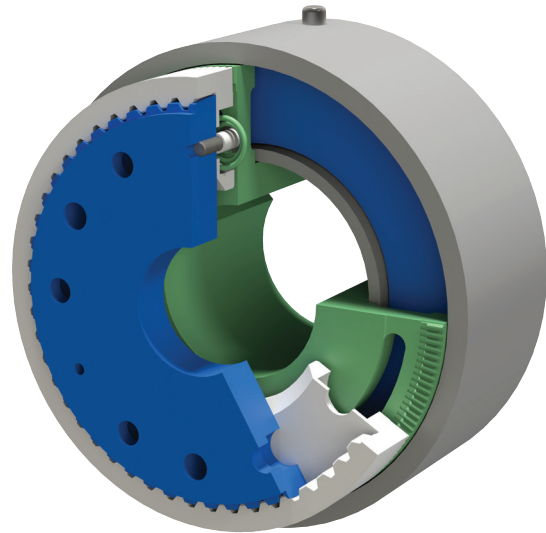

433.9

Performance/Mechanical Specifications

SFTC Series — Model Size

		320	375	450	525	630	760	895	1065
Torque Rating (Static)*	lb-ft	40	80	160	320	650	1300	2600	5200
	Nm	54.2	108.5	216.9	433.9	881.3	1762.6	3525.1	7050.2
Recommended Max Speed	RPM	3500	3000	2500	2000	1600	1500	1400	1400
Coil Data – 24VDC 110VDC									
	Amps	1.0 0.20	1.2 0.21	1.6 0.41	2.4 0.43	3.8 0.81	4.4 1.10	6.4 1.60	9.2 2.20
Rotor Inertia	lb-ft ²	0.01	0.02	0.03	0.05	0.15	0.31	0.62	1.3
	kg-cm ²	4.21	8.42	12.63	21.05	63.15	130.51	261.02	547.30
Armature/Adapter Inertia	lb-ft ²	0.01	0.02	0.04	0.08	0.18	0.43	0.73	1.85
	kg-cm ²	4.21	8.42	16.84	33.71	75.78	181.20	307.62	779.59
Approximate Weight	lb	3.0	5.0	8.0	12.0	23.0	37.0	48.0	100.0
	kg	1.36	2.27	3.63	5.44	10.43	16.78	21.77	45.36

*Refer to Design Considerations – General Notes & Data for dynamic rating.

SFTC Operation:

When current is applied to the coil in the stationary magnet body (held from rotating by an anti-rotation pin), a magnetic field is created which attracts the armature toward the rotor. As the teeth engage, torque is transmitted.

When the current is turned off, the armature slides on the splined output plate adapter. Springs pull on the armature to assist disengagement from the rotor.

Power On — Clutch Engaged

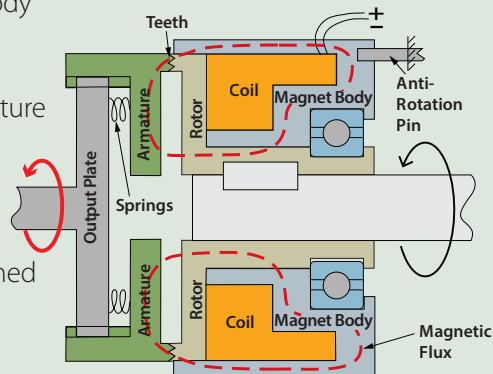

Power Off — Clutch Disengaged

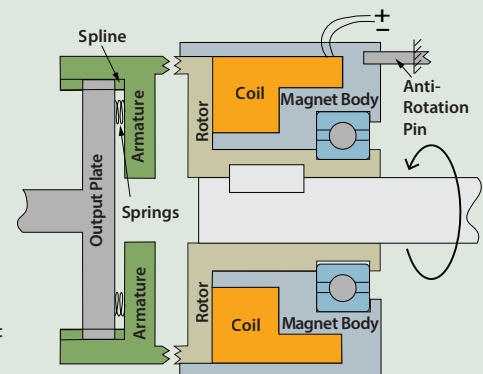

Tooth Clutches & Brakes

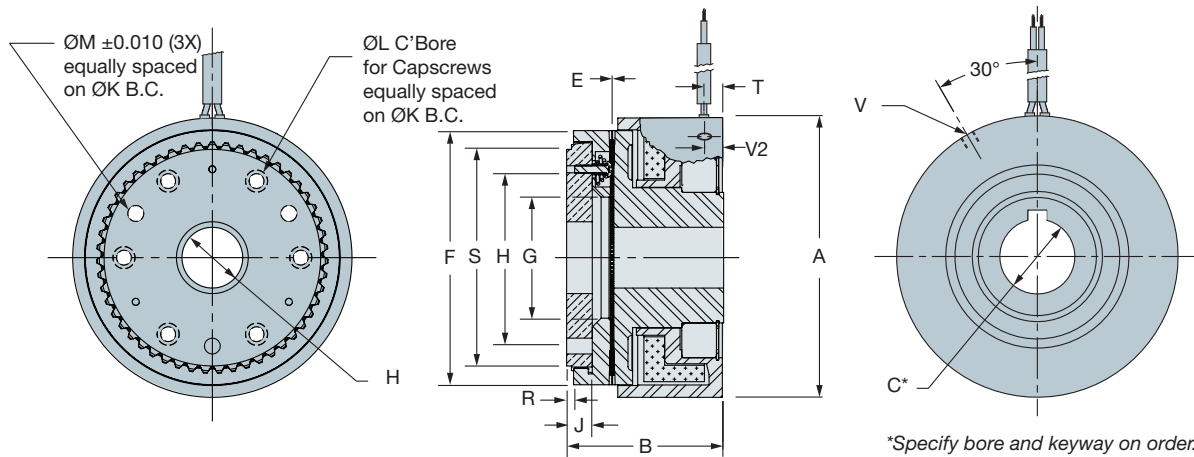

SFTC Series — Model Size

Dimensions — Inches (mm)		320	375	450	525	630	760	895	1065
Magnet Body Diameter	A	3.16 (80.26)	3.75 (95.25)	4.50 (114.30)	5.25 (133.35)	6.32 (160.53)	7.60 (193.04)	8.94 (227.08)	10.65 (270.51)
Overall Length (ref)	B	2.07 (52.58)	2.33 (59.18)	2.61 (66.29)	2.94 (74.68)	3.55 (90.17)	4.23 (107.40)	5.04 (128.02)	6.18 (156.97)
Rotor Bore	Min	C	0.500 (12.700)	0.750 (19.050)	1.000 (25.400)	1.125 (28.575)	1.375 (34.925)	1.750 (44.450)	2.250 (57.150)
	Max	C	1.000 (25.400)	1.250 (31.750)	1.500 (38.100)	1.750 (44.450)	2.250 (57.150)	2.750 (69.85)	3.500 (88.900)
	Length (ref)	D	1.49 (37.85)	1.69 (42.93)	1.85 (46.99)	2.06 (52.320)	2.48 (62.99)	2.97 (75.44)	4.10 (104.14)
Disengaged Clearance	E	0.010 (0.254)	0.012 (0.305)	0.014 (0.356)	0.016 (0.406)	0.018 (0.457)	0.020 (0.508)	0.024 (0.588)	0.028 (0.711)
Armature	Diameter	F	2.87 (72.90)	3.44 (87.38)	4.11 (104.39)	4.78 (121.41)	5.75 (146.05)	6.97 (177.04)	9.66 (245.36)
	Bore	G	1.26 (32.00)	1.52 (38.61)	1.87 (47.50)	2.13 (54.10)	2.74 (69.60)	3.35 (85.09)	4.31 (109.47)
	Bore (min.)	H	1.000 (25.400)	1.000 (25.400)	1.250 (31.750)	1.375 (34.925)	1.625 (41.275)	2.000 (50.800)	2.750 (69.85)
	Bore (max.)	H	1.690 (42.926)	2.000 (50.800)	2.340 (59.436)	2.760 (70.104)	3.320 (84.328)	4.120 (104.648)	5.875 (149.225)
Mounting Adapter	Thickness	J	0.31 (7.87)	0.34 (8.64)	0.41 (10.41)	0.48 (12.19)	0.58 (14.73)	0.70 (17.78)	1.00 (25.40)
	Bolt Circle	K	2.12 (53.85)	2.46 (62.48)	2.87 (72.90)	3.42 (86.87)	4.00 (101.60)	4.90 (124.46)	6.00 (152.40)
	Holes-Screw (Qty)	L	#10 (3)	#10 (3)	1/4 (3)	5/16 (3)	5/16 (6)	3/8 (6)	7/16 (6)
	Holes - Dowel	M	0.235 (5.969)	0.235 (5.969)	0.297 (7.544)	0.360 (9.144)	0.360 (9.144)	0.422 (10.719)	0.485 (12.319)
Adapter Protrusion	R	0.09 (2.29)	0.10 (2.54)	0.12 (3.05)	0.14 (3.56)	0.16 (4.06)	0.19 (4.83)	0.22 (5.59)	0.26 (6.60)
Adapter Diameter	S	2.69 (68.37)	3.10 (78.74)	3.70 (93.98)	4.30 (109.22)	5.75 (146.05)	6.10 (154.94)	7.25 (184.15)	8.25 (209.55)
Lead Wire Location	T	0.23 (5.84)	0.25 (6.35)	0.28 (7.11)	0.34 (8.64)	0.39 (9.91)	0.39 (9.91)	0.51 (12.95)	0.57 (14.48)
Anti-Rotation Hole	Depth - Max	V	0.29 (7.37)	0.33 (8.38)	0.34 (8.64)	0.47 (11.94)	0.53 (13.46)	0.75 (19.05)	0.86 (21.84)
	Thread Size		#10-32	#10-32	1/4-20	1/4-20	3/8-16	3/8-16	3/8-16
	Location	V2	0.22 (5.59)	0.25 (6.35)	0.28 (7.11)	0.34 (8.64)	0.39 (9.91)	0.39 (9.91)	0.51 (12.95)