

STCC Series

Stationary Field Tooth Clutch Couplings

Eight standard frame sizes available:

- 4.5 to 10.6" diameter ; 3.8 to 8.6" length
- Bore sizes from 0.8 to 2.9"
- Static torque from 160 to 5200 lb-ft
- 1400 to 2500 RPM max speed
- Operates both dry and in oil
- Modified designs and customized assemblies available



Performance/Mechanical Specifications

STCC Series — Model Size

		450	525	525A	630	630A	760	895	1065
Torque Rating (Static)*	lb-ft	160	320	320	650	650	1300	2600	5200
	Nm	216.9	433.9	433.9	881.3	881.3	1762.6	3525.1	7050.2
Recommended Max Speed	RPM	2500	2000	2000	1600	1600	1500	1400	1400
Coil Data – 24VDC	Amps	2.00	2.40	2.40	3.90	3.90	4.40	4.50	4.50
		110VDC	0.40	0.43	0.43	0.70	0.70	1.00	1.00
Approximate Weight	lb	11	16	16	31	31	50	65	110
	kg	5.0	7.3	7.3	14.1	14.1	22.7	29.5	49.9

*Refer to Design Considerations – General Notes & Data for dynamic rating.

STCC Operation:

When current is applied to the coil in the magnet body, a magnetic field is created which attracts the armature toward the rotor. As the teeth engage, torque is transmitted.

When the current is off, the armature slides on the splined hub to disengage from the rotor. Springs pull on the armature to assist. The bearing-mounted hub coupling assembly simplifies installation.

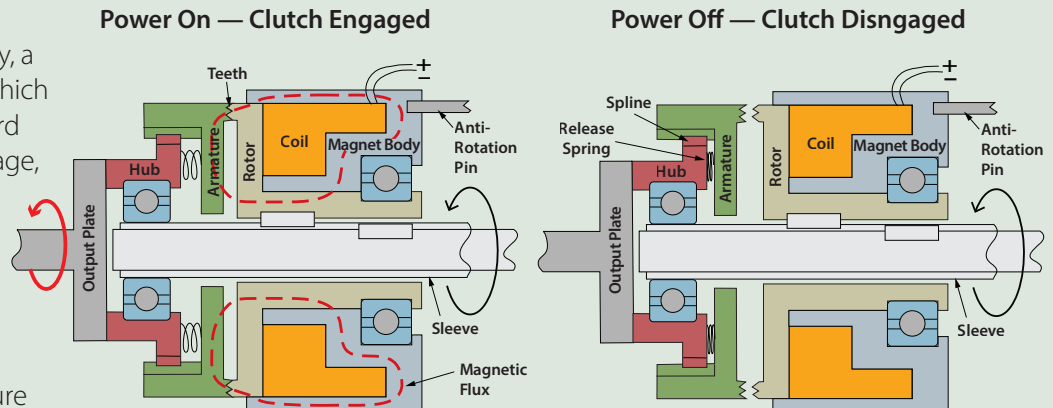

Tooth Clutches & Brakes

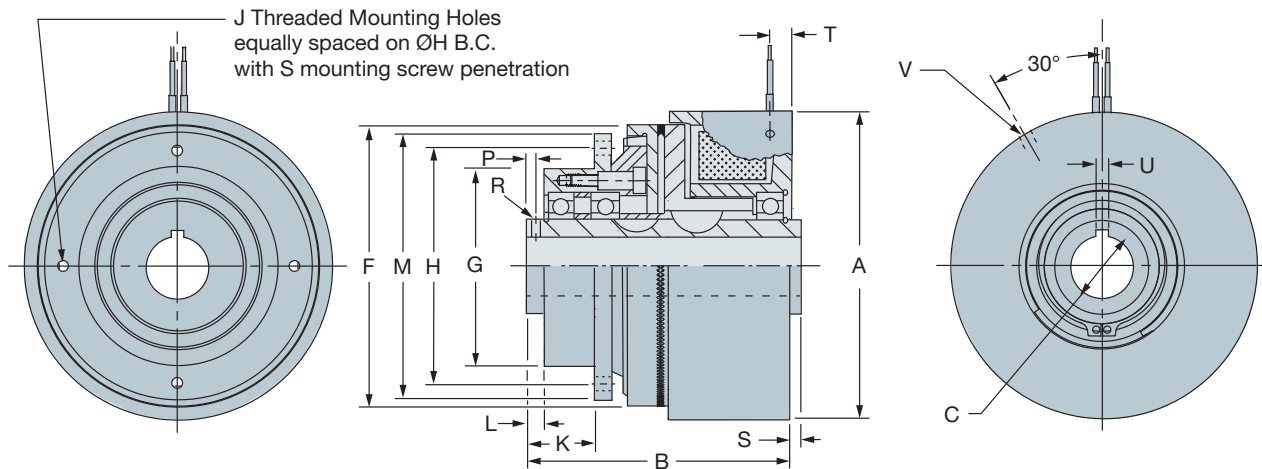

STCC Series — Model Size

Dimensions — Inches (mm)		450	525	525A	630	630A	760	895	1065
Magnet Body Diameter	A	4.50 (114.3)	5.25 (133.4)	5.25 (133.4)	6.32 (160.5)	6.32 (160.5)	7.60 (193.0)	8.94 (227.1)	10.65 (270.5)
Overall Length (ref)	B	3.88 (98.6)	4.12 (104.6)	4.12 (104.6)	4.62 (117.3)	5.01 (127.3)	5.38 (136.7)	6.22 (158.0)	8.62 (218.9)
Bore (+0.001/-0.000)	C	0.875 (22.23)	1.125 (28.58)	1.125 (28.58)	1.500 (38.10)	1.750 (44.45)	1.937 (34.80)	2.000 (50.80)	2.937 (74.60)
Armature	Diameter	F	4.11 (104.39)	4.78 (121.41)	4.78 (121.41)	5.75 (146.05)	5.75 (146.05)	6.97 (177.04)	9.66 (245.36)
	Mounting Pilot	G	2.874 (73.00)	3.499 (88.87)	3.499 (88.87)	4.124 (104.75)	4.499 (114.27)	5.249 (133.32)	7.374 (188.00)
	Mounting Hole B.C.	H	3.437 (87.30)	4.062 (103.18)	4.250 (107.95)	4.750 (120.65)	5.250 (133.35)	6.125 (155.58)	8.500 (215.90)
	Mounting Holes (Qty)	J	1/4-20 (4)	1/4-20 (4)	1/4-20 (4)	1/4-20 (4)	5/16-18 (4)	5/16-18 (4)	1/2-13 (6)
	End to Pilot Flange	K	0.97 (24.6)	1.00 (25.4)	1.00 (25.4)	1.16 (29.5)	1.16 (29.5)	1.28 (32.5)	1.50 (38.1)
Mounting Flange Adapter	End to Pilot Face	L	0.25 (6.4)	0.31 (7.9)	0.31 (7.9)	0.35 (8.9)	0.35 (8.9)	0.38 (9.7)	0.69 (17.5)
	Flange Diameter	M	3.88 (98.6)	4.50 (114.3)	4.88 (124.0)	5.38 (136.7)	6.00 (152.4)	8.22 (208.0)	9.50 (241.3)
	Flange Width	N	0.25 (6.4)	0.25 (6.4)	0.25 (6.4)	0.31 (7.87)	0.31 (7.87)	0.50 (12.7)	0.50 (12.7)
	Screw Penetration (Max)	O	0.31 (7.9)	0.31 (7.9)	0.31 (7.9)	0.38 (9.7)	0.38 (9.7)	0.62 (15.8)	0.62 (15.8)
	Set Screw Location	P	0.12 (3.0)	0.12 (3.0)	0.12 (3.0)	0.22 (5.6)	0.22 (5.6)	0.38 (9.7)	0.50 (50.8)
	Set Screw Size x Depth (Qty 2)	R	#10-32 x1/4	#10-32 x3/8	#10-32 x3/8	1/4-20 x3/8	1/4-20 x3/8	3/8-16 x1/2	5/8-11 x5/8
Alternative Sleeve Position	S	0.20 (5.1)	0.25 (6.4)	0.25 (6.4)	0.31 (7.9)	0.31 (7.9)	0.31 (7.9)	0.57 (14.5)	0.81 (20.6)
Lead Wire Location	T	0.31 (7.9)	0.34 (8.6)	0.34 (8.6)	0.39 (9.9)	0.39 (9.9)	0.39 (9.9)	0.51 (13.0)	0.57 (14.5)
Keyway Size	U	3/16x3/32	1/4x1/8	1/4x1/8	3/8x3/16	3/8x3/16	1/2x3/16 (2x)	1/2x1/4	3/4x1/4 (2x)
Anti-Rotation Hole	Depth - Max	V	0.34 (8.6)	0.47 (11.9)	0.47 (11.9)	0.53 (13.5)	0.53 (13.5)	0.75 (19.1)	0.73 (19.1)
	Thread Size		1/4-20	1/4-20	1/4-20	3/8-16	3/8-16	3/8-16	3/8-16