

PMB Series

Permanent Magnet Power-Off Brakes

Nine standard frame sizes available:

- 1.1 to 6.3" diameter ; 1.1 to 3.6" length
- Bore sizes from 6 to 40 mm
- Static torque from 0.3 to 103.3 lb-ft
- 24 VDC coil voltage
- Dry operation
- Modified designs and customized assemblies available

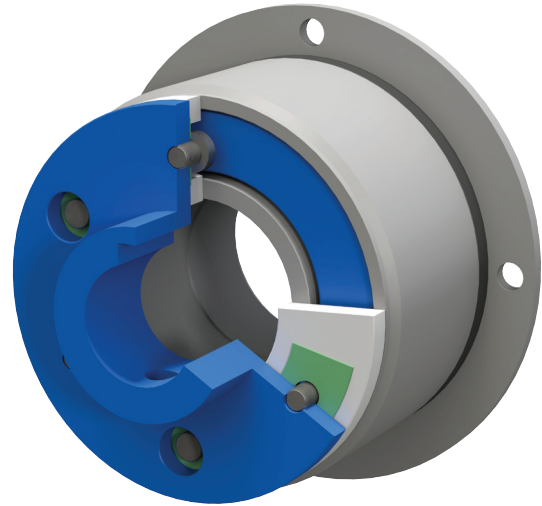

PMB Series — P/N - Model Size

Performance/ Mechanical Specifications	SEPAC P/N:	10138	10139	10140	10141	10142	10143	30127	30128	30129
	SIZE:	110	126	157	197	252	319	398	496	634
Torque Rating (Static)	lb-ft	0.3	0.7	1.5	3.3	6.6	13.3	26.6	53.1	103.3
	Nm	0.4	1.0	2.0	4.5	9.0	18.0	36.0	72.0	140.0
Coil Data – 24VDC	Watts	8	10	11	12	18	24	26	40	50
Approximate Weight	lb	0.22	0.24	0.44	0.77	1.21	1.87	3.53	6.39	11.90
	kg	0.10	0.11	0.20	0.35	0.55	0.85	1.60	2.90	5.40

A complete model part number includes the coil voltage and armature hub bore diameter (dim. "d") added to the series and model size (overall body diameter). Metric armature hub bores are identified with an "M". For example: PMB-110-24-M06, PMB-126-24-M06, etc.

PMB Operation:

With current off to the electric coil, the permanent magnet provides ongoing magnetic flux to engage the armature plate with the brake's inner and outer friction faces. The load attached to the hub/diaphragm spring/armature plate assembly is held continuously without power consumption.

When current is applied to the coil, the permanent magnet flux path is counteracted, thereby reducing the magnetic force at the friction face contact points to zero. This allows the diaphragm spring to pull the armature plate away from the magnet case, allowing the load to rotate freely — only while power is applied to the coil.

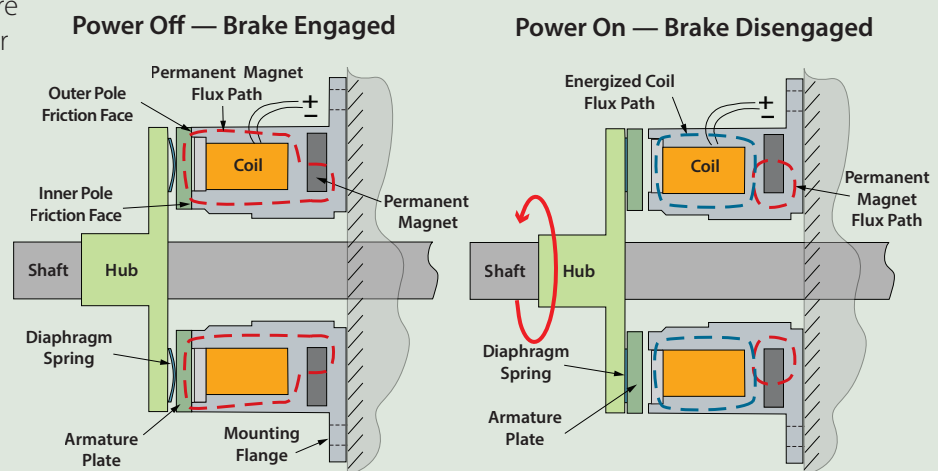

Power-Off Holding Brakes

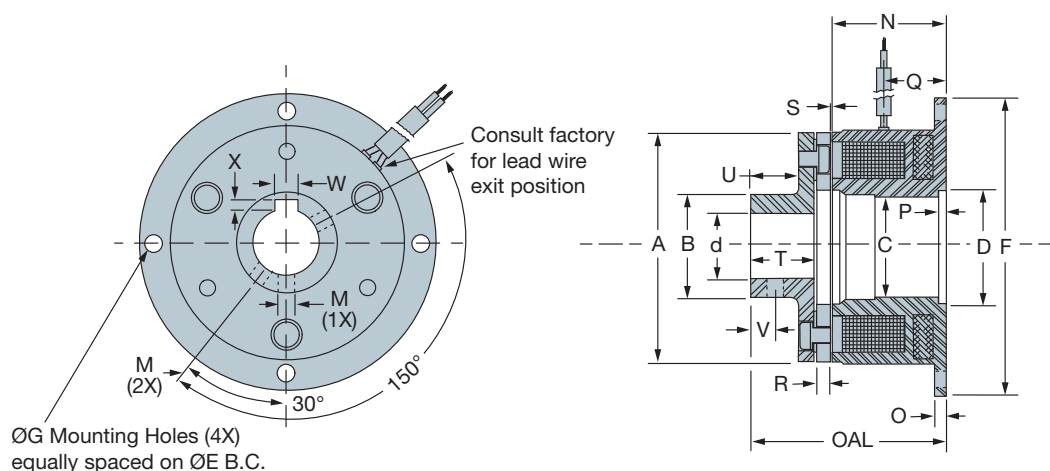

PMB Series — Model Size

Dimensions — Inches (mm)		110	126	157	197	252	319	398	496	634	
Overall Body Diameter	A	1.10 (28)	1.26 (32)	1.58 (40)	1.97 (50)	2.52 (64)	3.19 (81)	3.98 (101)	4.96 (126)	6.34 (161)	
Overall Length (ref)	OAL	1.14 (29)	1.33 (34)	1.50 (38)	1.73 (44)	1.82 (46)	2.16 (55)	2.58 (66)	2.99 (76)	3.58 (91)	
Ø (ID)	C	0.43 (11.0)	0.49 (12.5)	0.75 (19.0)	0.94 (24.0)	1.26 (32.0)	1.50 (38.0)	1.91 (48.5)	2.28 (58.0)	2.95 (75.0)	
Thickness	N	0.77 (19.5)	0.85 (21.5)	0.89 (22.5)	1.12 (28.5)	1.06 (26.8)	1.18 (29.9)	1.33 (33.9)	1.49 (37.8)	1.68 (42.6)	
Lead Wire Location	Q	0.39 (10.0)	0.47 (12.0)	0.47 (12.0)	0.55 (14.0)	0.59 (15.0)	0.65 (16.5)	0.75 (19.0)	0.91 (23.0)	1.02 (26.0)	
Case	Mounting Flange Ø	F	1.54 (39.0)	1.77 (45.0)	2.13 (54.0)	2.56 (65.0)	3.15 (80.0)	3.94 (100.0)	4.92 (125.0)	7.48 (190.0)	
	Mounting Hole Ø	G	0.13 (3.4)	0.13 (3.4)	0.13 (3.4)	0.13 (3.4)	0.18 (4.5)	0.22 (5.5)	0.25 (6.3)	0.26 (6.5)	0.35 (9.0)
	Mounting Holes Bolt Circle	E	1.319 (33.50)	1.496 (38.00)	1.850 (47.00)	2.283 (58.00)	2.835 (72.00)	3.543 (90.00)	4.409 (112.00)	5.394 (137.00)	6.890 (175.00)
Pilot	Ø	D	0.43 (11.0)	0.49 (12.5)	0.75 (19.0)	1.02 (26.0)	1.38 (35.0)	1.65 (42.0)	2.05 (52.0)	2.44 (62.0)	3.15 (80.0)
	Depth	P	—	—	—	0.07 (1.8)	0.08 (2.0)	0.08 (2.0)	0.10 (2.5)	0.14 (3.5)	0.14 (3.5)
Ø (OD)	B	0.53 (13.5)	0.59 (15.0)	0.67 (17.0)	0.94 (24.0)	1.08 (27.5)	1.22 (31.0)	1.61 (41.0)	1.93 (49.0)	2.56 (65.0)	
Bore Ø	d	0.236 (6.00)	0.236 (6.00)	0.394 (10.00)	0.591 (15.00)	0.709 (18.00)	0.787 (20.00)	1.181 (30.00)	1.181 (30.00)	1.575 (40.00)	
Length	T	0.28 (7.0)	0.39 (10.0)	0.47 (12.0)	0.47 (12.0)	0.59 (15.0)	0.79 (20.0)	0.98 (25.0)	1.18 (30.0)	1.50 (38.0)	
Hub	Collar Length	U	0.20 (5.0)	0.31 (8.0)	0.37 (9.5)	0.35 (9.0)	0.45 (11.5)	0.63 (16.0)	0.79 (20.0)	0.94 (24.0)	1.22 (31.0)
Set Screw	Thread (Qty)*	M	M3 (1X)	M3 (1X)	M4 (1X)	M4 (1X)	M5 (2X)	M5 (2X)	M6 (2X)	M6 (2X)	M8 (2X)
	Location	V	0.10 (2.5)	0.16 (4.0)	0.16 (4.0)	0.20 (5.0)	0.24 (6.0)	0.31 (8.0)	0.39 (10.0)	0.47 (12.0)	0.55 (14.0)
Keyway	Width	W	0.079 (2.00)	0.079 (2.00)	0.118 (3.00)	0.197 (5.00)	0.236 (6.00)	0.236 (6.00)	0.310 (8.00)	0.280 (7.00)	0.390 (10.00)
	Height	X	0.039 (1.00)	0.039 (1.00)	0.055 (1.40)	0.091 (2.30)	0.110 (2.80)	0.110 (2.80)	0.130 (3.30)	0.130 (3.30)	0.150 (3.80)
Armature Plate Thickness (including spring)	R	0.090 (2.20)	0.080 (2.10)	0.110 (2.70)	0.120 (3.00)	0.160 (4.00)	0.180 (4.50)	0.250 (6.40)	0.280 (7.20)	0.370 (9.40)	
Air Gap (nominal ref)	S	0.006 (0.15)	0.010 (0.25)	0.010 (0.25)	0.012 (0.30)	0.012 (0.30)	0.012 (0.30)	0.012 (0.30)	0.018 (0.45)	0.031 (0.80)	

* With one set screw positioned 180° from keyway; positioned as shown for M (2X) when there are two set screws.